

## COMPRESSOR SOLUTIONS

**LB601-LC**  
LPG Unloading  
Compressors  
Driven @ 715 RPM

Gas: Propane  
n = 1.13  
MW = 44.09

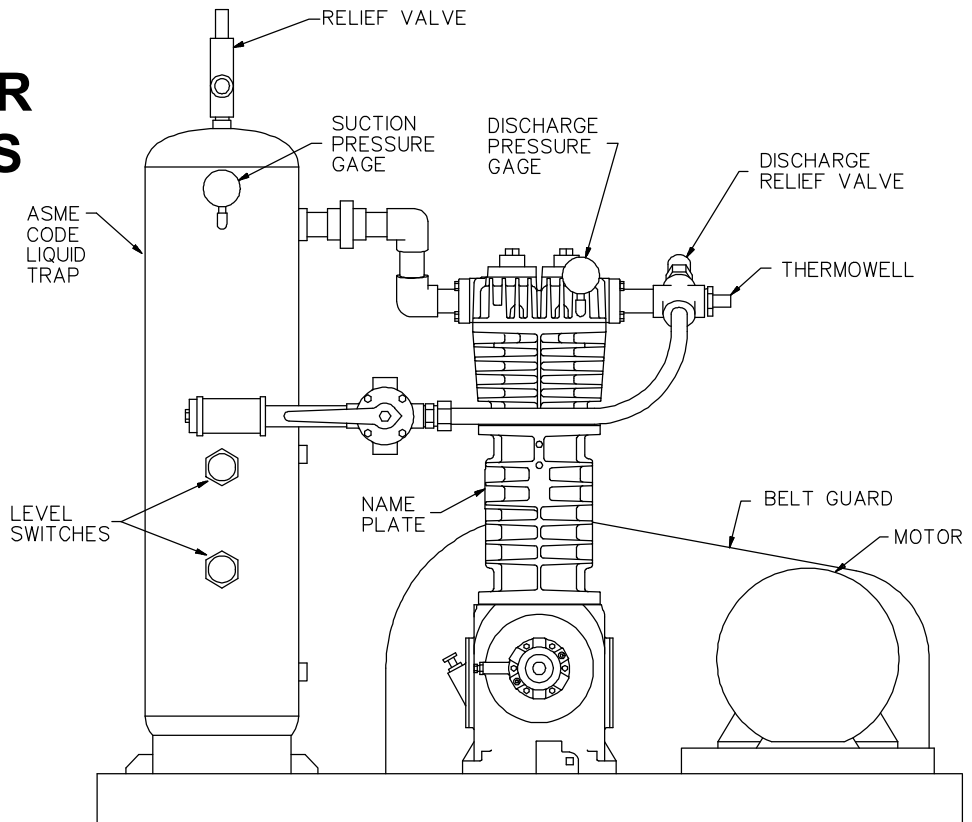

AE92-98844-1

Inlet: 35 - 189 psia at 20 - 100°F (2.5 - 13.3 kg.cm<sup>2</sup> a at -7 - 38°C)

Outlet: 75 - 220 psia (5.3 - 15.5 kg/cm<sup>2</sup> a)

### FEATURES

Buna-N O-rings	Ductile Iron	Aluminum Gaskets
Pressure Gauges	Relief Valves	Suction Strainer
ASME Code Liquid Trap	25 HP Motor	Liquid Level Switch
4-Way Flow Control Valve		

Four of these units are being used in China to transfer LPG at up to 300 gpm (1,135 lpm). A 4-way flow control valve allows vapors to be recovered after all the liquid has been transferred. The liquid trap, which prevents entry of liquid into the compressor, includes an electrical float switch to monitor the liquid level in the trap to protect the compressor in the event of abnormal operation. An inlet strainer stops foreign material from entering the compressor while relief valves prevent excessive pressures. The motor and switch are explosion proof.