

COMPRESSOR SOLUTIONS

LB601-LU & LB361-LU
Liquid Transfer and
Vapor Recovery Units
driven @ 715 RPM
and 745 RPM

Gas:
Propane
n=1.13 MW=44.1

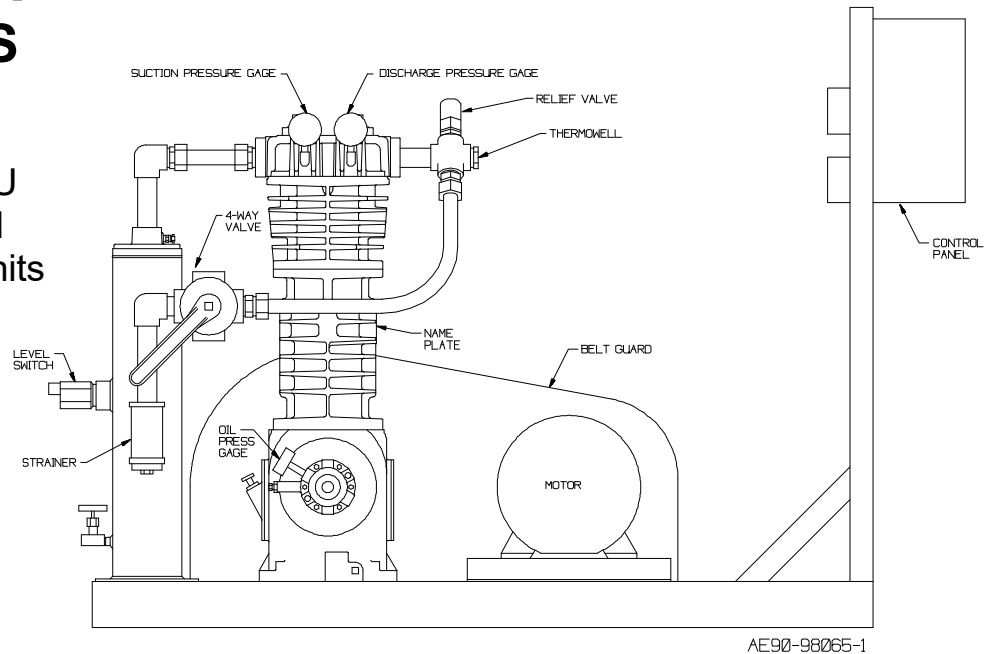

Inlet:
71 - 114 psig (5 - 8 kg/cm²g), Ambient Temperature
Outlet:
213 - 261 psig (15 - 18.4 kg/cm²g)

Compressor Trim: Buna-N O-rings and Aluminum Gaskets

Accessories: 30 HP Motor (15 HP on the LB361), Liquid Trap with Float Switch, suction strainer, 4-way flow control valve, High Discharge Temperature Switch with Thermowell, Low Oil Pressure switch, Discharge relief valve, Pressure Gauges for suction and discharge gas pressures and crankcase oil pressure. All electrical devices are explosion proof and are on 50 Hz operation.

Two LB601s and a LB361-LU are being used to transfer Propane from rail tank car to storage in China. These are typical Propane transfer compressors with both a liquid trap and a 4-way flow control valve. The trap prevents entry of liquid into the compressor and the 4-way valve allows both liquid transfer and recovery of vapors. The strainer, level switch, temperature switch, oil pressure switch, and relief valve all help protect the compressor from various potential problems.